

ARGO 6x6
BIGFOOT



ARGO

BIGFOOT

PARTS MANUAL

From Serial # ...14916

Foreword

ODG has prepared this parts manual for the BIGFOOT model to assist both qualified mechanics and vehicle owners in ordering correct, quality replacement ARGO parts.

Proper and regular service, and replacing old, worn or broken parts with the correct ARGO replacement parts, are both essential to prolonging the life of the ARGO. Please refer to this parts manual before ordering any replacement part.

All information contained in this BIGFOOT Parts Manual is based on the latest product specification available at time of printing. If your BIGFOOT differs from the specifications contained in this manual, contact Ontario Drive & Gear Limited for information.

ODG reserves the right to alter specifications on the BIGFOOT model at any time, without obligation or prior notification.

Reproduction of the BIGFOOT Parts Manual, in whole or in part, is prohibited without prior written permission from Ontario Drive & Gear Limited.

Vehicle Identification

BIGFOOT - Serial Nos. B14916

Explanation of Parts Manual Format

Ref	- Reference number between assembly diagram and component parts list
Part No.	- Argo replacement part number for identification and re-ordering
Description	- Part description for identification and re-ordering
Qty	- Indicates the quantity of a part used in an Assembly

ARGO 6x6 BIGFOOT



Using the Parts Manual

1. Find the major vehicle assembly in the Table of Contents on this page, and turn to that section.
2. Locate the part in the illustration that you wish to order.
3. Refer to the parts list in that section.
4. Find the correct part number (Part No.), part description (Description) and correct quantity (Qty).
5. Use *only* this information to order ARGO replacement parts. *DO NOT* attempt to order a replacement part by reference number or page number.

Table of Contents

Foreword	i
Model Identification	i
Using the Parts Manual	ii
1.0 Transmission	1
2.0 Intake and Exhaust System	3
3.0 Clutch System	4
4.0 Power Pack Assembly	5
5.0 Steering & Brake System	7
6.0 Vehicle Body & Firewall	9
7.0 Frame & Drive System	11
8.0 Fuel System & Seat Assembly	13
9.0 Electrical System	15

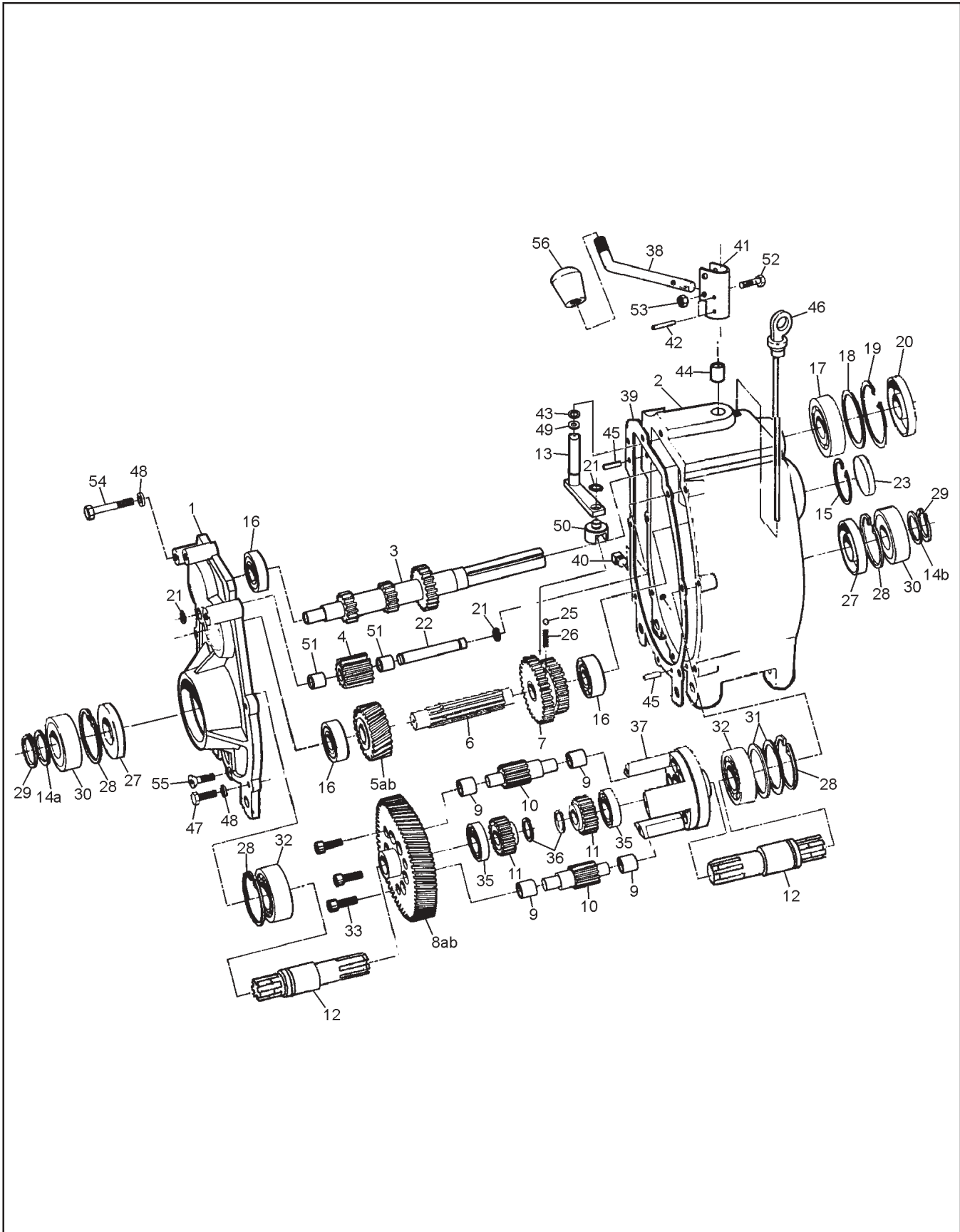

Ref.	Qty.	Part #	Description
.	1	610-18H	Transmission Asm - H,does not include Refs 38, 52, 53 & 56
1	1	34-68	Cover, Transmission
2	1	34-99	Housing, Transmission
3	1	34-21	Shaft, Input - 13/21T
4	1	34-16A	Gear, Idler 13T
5a	1	34-96	Gear, Helical - 26T-H
5b	1	34-95	Gear, Helical - 24T-M
6	1	34-94	Shaft, Spline
7	1	34-91	Gear, Double - 26/33T
8a	1	34-43	Gear Plate - 71T-H
8b	1	34-22	Gear Plate - 73T-M
9	12	105-03	Bushing, Oilite ½ x ¾
10	6	34-13	Gear, Planet - 12T
11	2	34-14	Gear, Sun - 21T
12	2	34-98	Shaft, Output
13	1	34-65	Shifter Asm
14a	1	114-04	Washer, Shim .040 Thk
14b	1	114-05	Washer, Shim .020 Thk
15	1	106-01	Retaining Ring
16	3	101-01	Bearing, Ball 6204Z-C3
17	1	101-16	Bearing, Ball 6206-C3
18	as req.	114-02	Washer, Shim 2.06x2.42x.02
19	1	106-05	Retaining Ring
20	1	102-05	Seal, Oil WBS 30x62x10
21	3	107-05	Retaining Ring
22	1	34-11	Pin, Dowel ½ x 3.50
23	1	31-07	Plug Plate
25	1	109-05	Ball, Steel 6mm 62-67 Rc
26	1	34-32	Spring, Compression - 7/32 x 0.50
27	2	102-03	Seal, Oil WBS 30x72x10
28	4	106-03	Retaining Ring
29	2	107-02	Retaining Ring
30	2	101-05	Bearing, Ball 6306-2NSE C3
31	2	114-01	Washer, Shim 2.25x2.81x.02
32	2	101-03	Bearing, Ball 6207-C3
33	3	103-04	SHCS 5/16-18 x 1.0 Bare
35	2	101-15	Bearing, Ball 6005-C3
36	2	107-04	Retaining Ring
37	1	34-08	Cage
38	1	610-77	Lever, Shift
39	1	34-47	Gasket, Cover - 1/64"Thk
40	1	103-02	Plug, Magnetic 3/8 - 18 NPT Sq. Hd.
41	1	34-86	Holder, Shift Lever
42	2	111-01	Pin, Spring 5/32 x 1.00 - Slotted
43	1	113-01	O-Ring
44	1	105-02	Bushing, Oilite 1/2x 1.0
45	2	104-03	Pin, Dowel 1/4 x 7/8
46	1	34-77	Dipstick - with Breather
47	4	103-06	HHCS 5/16-18x1.0 GR5 Zn
48	7	108-05	Lockwasher 5/16 Zn
49	1	108-74	Washer .64 x .875 x .10 Zn
50	1	34-63	Shift Yoke
51	2	101-79	Bearing, Drawn Cup Needle
52	1	103-97	HHCS 1/4-20x1.25 GR5 Zn
53	1	117-27	Locknut, Nylon 1/4-20 Zn
54			See Section 4.0 Power Pack Assembly
55	1	103-95	FHSC 5/16-18x1.0 GR8 Zn
56	1	126-38	Knob, Shift

2.0 Intake and Exhaust System

Bigfoot Parts Manual

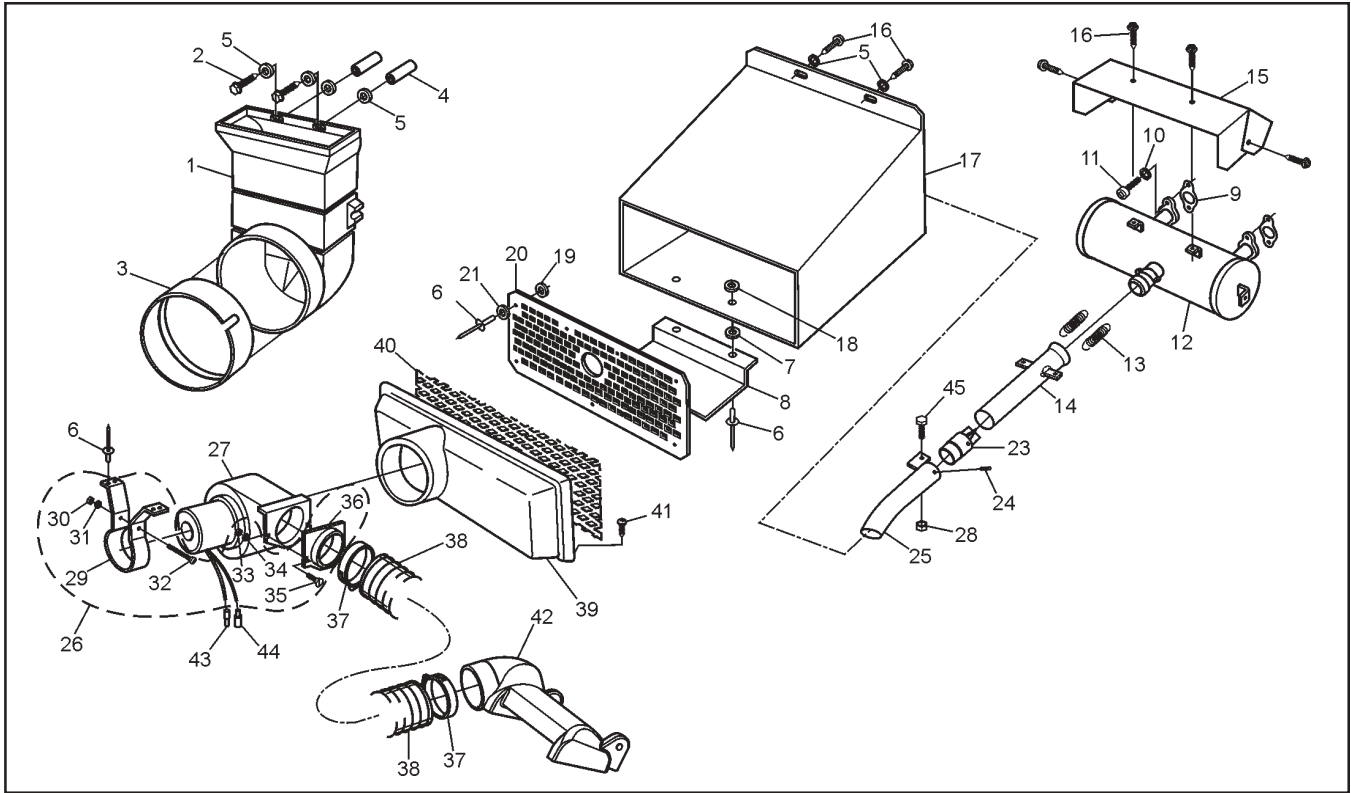

Ref.	Qty.	Part #	Description	Ref.	Qty.	Part #	Description
1	1	603-97	Duct, Intake	26	1	125-92	Adpt. & Mounting Kit - Fan (incl. Refs 29 to 36)
2	2	112-48	Screw, T/S HH#14x2.25 Zn	27	1	125-91	Blower Fan
3	1	603-82	Seal	28	1	117-81	Locknut, 2-way 1/4-20 Zn
4	2	120-29	Spacer, .26 ID x 1.12 LG	29	1		Mounting Bracket
5	6	108-08	Washer, .28 x .62 x .04 Zn	30	1		Nut, #10-32
6	13	120-13	Rivet 3/16 x 5/8 - Black	31	1	See	Lockwasher, 3/16"
7	2	125-58	Washer, Fibre - W-77F	32	1	125-92	Screw, #10-32 x 2"
8	1	707-28	Support, Exhaust Duct	33	2	Above	Nut, 1/4-20
9	2	805024	Gasket	34	2		Lockwasher, 1/4"
10	4	108-02	Lockwasher 5/16 Hi-Collar Bare	35	2		Screw, 1/4-20 x 5/8"
11	4	112-30	SHCS M8x1,25x20mm Zn	36	1		Adaptor, 3" Dia.
12	1	807-90	Muffler, B&S V-Twin Weld Ass'y	37	2	125-35	Clamp, Gear 3.50" HF-52
13	2	126-57	Spring, Extension- 7/16x2.14	38	1	127-44	Hose, Intake 3" dia. x 46"
14	1	807-92	Pipe, Mufflertail - B&S	39	1	601-89	Intake Flange (specify colour)
15	1	807-85	Shield, Muffler Heat	40	1	126-61	Intake Screen
16	6	112-19	Screw, IHWH T/C Slot 1/4-20x 1/2	41	4	112-56	Pan HD Phil T/S #10x3/4 A Zn
17	1	707-32	Duct, Exhaust	42	1	128-01	Duct, Brake Cooling
18	2	120-04	Washer .19x.50x.08 Zn	43	1	118-02	Terminal, Male #76-1251
19	7	120-05	Washer .19x.50x.04 Zn	44	1	118-03	Terminal, Female#76-1289
20	1	707-31P	Screen, Exhaust	45	1	112-04	HHCS, 1/4-20 x 3/4 Gr2 Zn
21	7	125-59	Washer, Fibre -.062x.25x.50				
23	1	807-67	Spark Arrester				
24	1	112-43	Screw, IHWH #8x3/8				
25	1	807-89	Tube, Tailpipe Outlet				

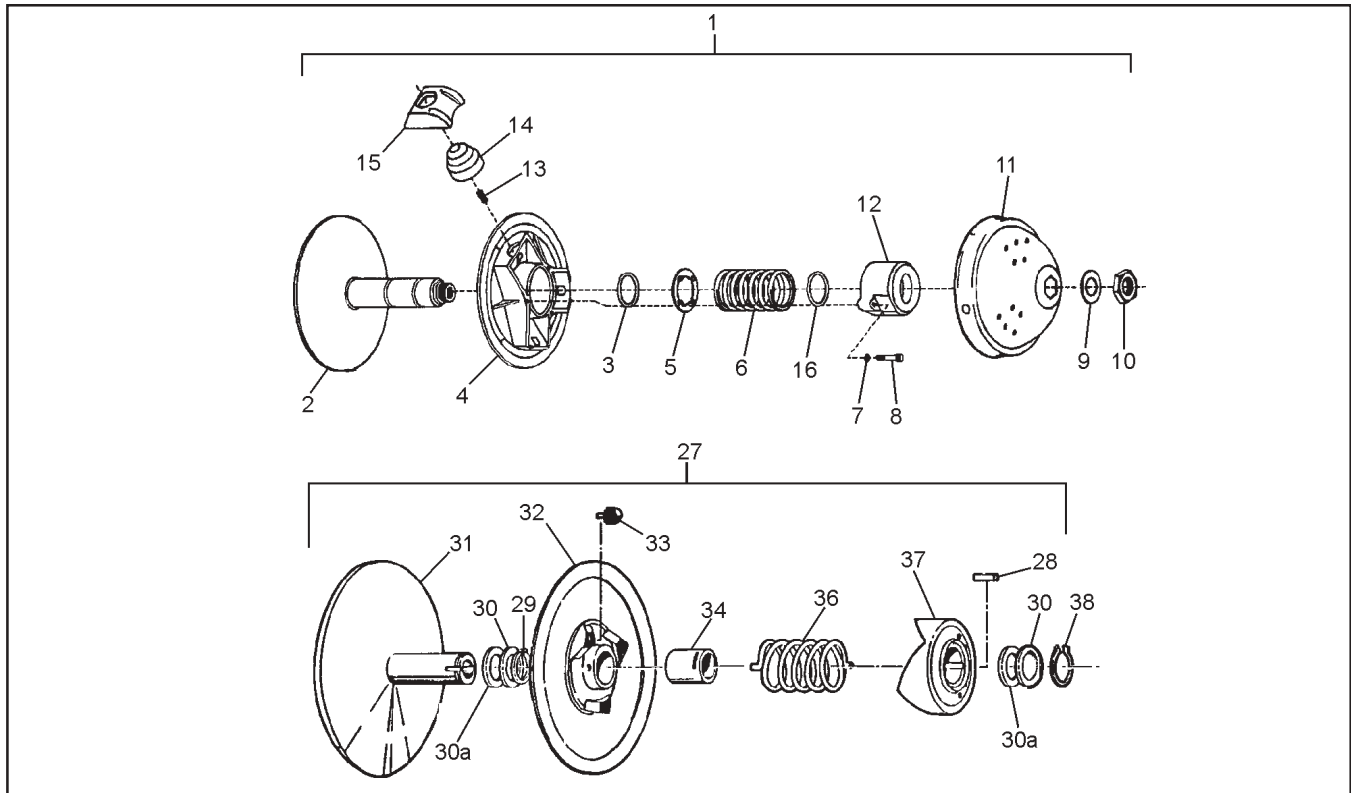

Ref.	Qty.	Part #	Description
1	1	127-73	Clutch, Driver (incl. Refs 2-15)
2	1	0405-0043	Pulley, Fixed half
3	1	0410-0007	Pulley, Sliding half
4	1	V08	Retaining Ring
5	1	V09	Plate, Spring Guide
6	1	V10-48-103-18	Spring
7	1	0440-0001	Cover, Spring
8	3	420-2453-700	Washer, Lock
9	3	222-9640-66	SHCS
10	3	0130-3002	Block, Red
11	3	C13-225	Weight, Lead 225g
12	3	C24-L1	Spring, Anti-noise
13	1	0115-0003(A)	Cap
14	1	0080-0153	Washer Zn
15	1	0080-0100	Nut
16	1	V08C	Spring Ring
27	1	127-129	Clutch, Driven - Model "B" (incl. Refs 28-37)
28	1	ASK-5	Key 1/4 x 1/4 x 5/8
29	1	ASR-6	Retaining Ring
30	as req	ASA-1	Spacer .050" Thick
30a	as req	ASA-1-S	Spacer .025" Thick
31	1	AFK25.4-250OD01	Pulley, Half - Fixed
32	1	AMC-2-250OD01	Pulley, Half - Sliding incl. Refs. 33 & 34
33	3	ANS-2-T	Shoe, Cam
34	1	5040-3003	Bushing, Super Oilite
36	1	ACS-3-188	Spring, Blue
37	1	AFC-4-C3D4	Cam
38	1	371-9031-000	Retaining Ring

4.0 Power Pack Assembly

Bigfoot Parts Manual

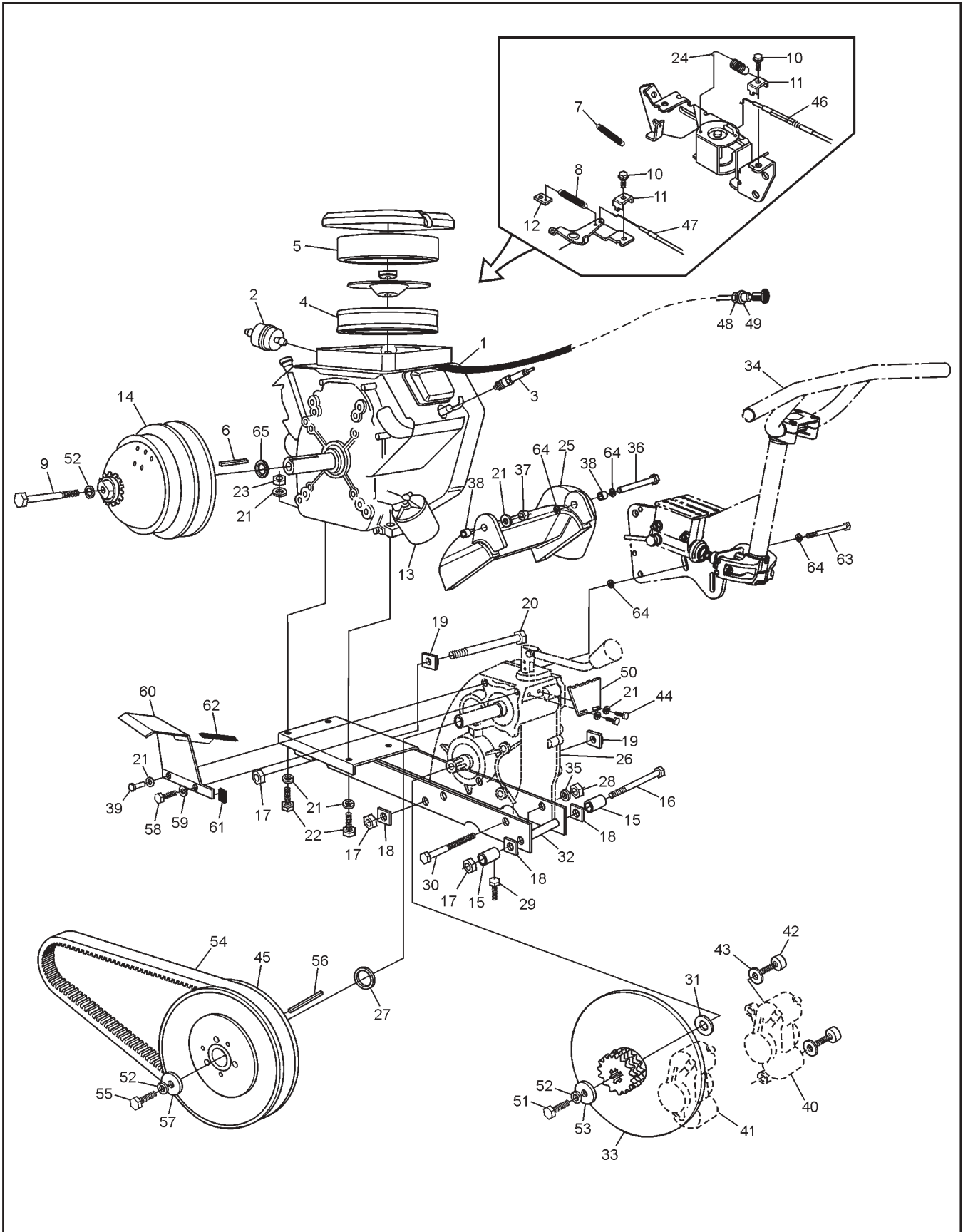

Bigfoot Parts Manual

4.0 Power Pack Assembly

Ref.	Qty.	Part #	Description	Ref.	Qty.	Part #	Description
1	1	128-15	Engine-B&S 18HP, 20/50amp incl. Ref.2-12, 13 B&S #356447-0165-E1, 24	37	1	117-21	Locknut, Nylon 5/16-18 Zn
2	1	125-64	Fuel Filter, G81-4	38	2	108-71	Spacer, 5/16 ID x 7/16 OD x 13/32 Lg
3	2	126-74	Spark Plug #3926	39	1	103-38	HHCS 5/16-18 x 1.25 Gr5 Zn
4	1	394018	Filter, Air	40to41			See Section 5.0 Brake & Steering System
5	1	272490	Element, Foam	42	4	103-41	SHCS 3/8-16 x 1.25 Zn
6	1	110-03	Key 1/4x3/16x2.375 RC46	43	4	108-23	Washer 3/8 SAE Gr8 - Dich.
7	1	805458	Spring	44	2	112-01	HHCS 5/16-8x3/4 Gr5 Zn
8	1	125-88	Spring, Return	45			See Section 3.0 Clutch System
9	1	112-28	HHCS 3/8-24x4.5 Gr5 Zn	46	1	612-101	Cable Asm, Throttle
10	1	805169	Screw-Hex Head (Briggs #)	47	1	612-92	Cable Asm, Choke
11	1	221535	Clamp - Casing (Briggs #)	48	2	117-68	Nut, Jam 3/8-24 UNF Zn
12	1	601-86	Clip, Retainer	49	1	108-32	Lockwasher 3/8 Int. Tooth
13	1	126-95	Filter, Oil	50	1	610-81	Shift Gate, Transmission
14			See Section 3.0 Clutch System	51	2	103-18	HHCS 3/8-24x1.25 Gr5 Zn
15	2	811-14	Spacer	52	2	108-06	Lockwasher 3/8 S/R Zn
16	1	112-57	HHCS 5/8-11x10.0 Gr5 Zn	53	2	108-18	Washer 13/32x1.375x11GA
17	3	117-09	Locknut, Nylon 5/8 Zn	54	1	125-56	Drive Belt
18	3	811-09	Washer, Square Lock .64 ID	55	1	103-34	HHCS 3/8-16x1.25 Gr5 Zn
19	2	811-15	Washer, Square Lock .64 ID	56	1	110-09	Key 1/4 x 1/4 x 3.0
20	2	112-58	HHCS 5/8-11x7.5 Gr5 Zn	57	1	108-46	Washer .40 x 1.37 x .12 Hi- Carbon
21	10	108-24	Washer 5/16 SAE Zn	58	2	103-17	HHCS 3/8-16x1.0 Gr5 Zn
22	4	112-27	HHCS 5/16-18x1.75 Gr5 Zn	59	2	108-26	Washer 3/8 Zn
23	4	117-21	Locknut, Nylon 5/16-18 Zn	60	1	603-29	Guard, Belt Protect
24	1	127-49	Spring, Return	61	1	601-92	Trim, Vinyl - 1.5"
25	1	128-01	See Section 2.0 Intake & Exhaust System	62	1	601-93	Trim, Vinyl - 4.25"
26			See Section 1.0 Transmission	63	2	103-55	HHCS 5/16-18x2.75 Gr5 Zn
27	as req	108-36	Washer .06x1.00x1.375 Zn	64	6	108-24	Washer .34 x .70 x .06 Zn
28	2	117-06	Nut, Fin Hex 1/2-13 Zn	65	1	114-04	Washer, Shim 1.19 x 1.50 x .04
29	2	103-53	HHCS 3/8-16x3.0 Full Thread				
30	2	103-20	HHCS 1/2-13x6.5 Gr5 Zn				
31	as req	108-75	Washer, Shim 1"ID x .5 x .010 - right hand disc only				
32	1	611-71	Frame, Power Pack				
33	2	610-80	Brake Disc - #50-2 x 13T				
34			See Section 5.0 Steering & Brake System				
35	2	108-07	Lockwasher 1/2 Zn				
36	1	112-132	HHCS 5/16-18 x 3.25 Gr5 Zn				

5.0 Steering & Brake System

Bigfoot Parts Manual

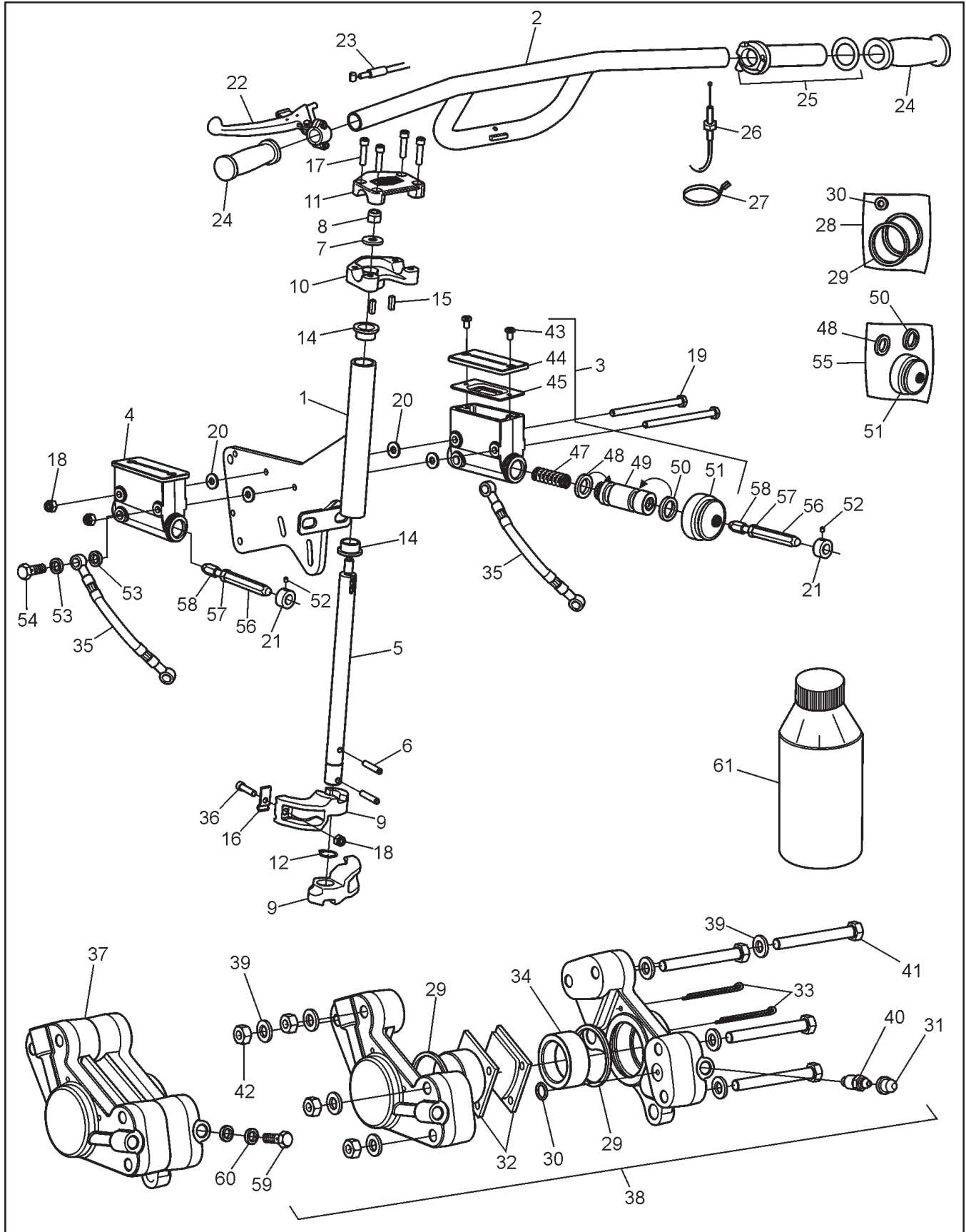

Bigfoot Parts Manual

5.0 Steering & Brake System

Ref.	Qty.	Part #	Description	Ref.	Qty.	Part #	Description
1	1	612-117	Frame Assembly, Steering Column	40	2x1	168-02	Screw, Bleeding, Knott Caliper
2	1	612-107	Handlebar Assembly	41	2x4	112-154	SHCS 5/16-18 x 2.75 Zn
3	1	165-08	Master Cylinder, Grimeca - R	42	2x4	117-03	Nut, Fin Hex 5/16-18 Zn
4	1	165-07	Master Cylinder, Grimeca - L	43	2x2	160-42	FHMS M5 x 0,8 x 6mm
5	1	612-127	Shaft, Steering - Argo	44	2x1	168-08	Cover
6	2	104-07/PI	Pin, Spring 1/4 x 1.25	45	2x1	168-09	Cover, Rubber
7	1	108-47	Washer, .39 x .94 x .13 Zn Di-chr	47	2x1	162-08	Spring, Comp. 17.3 x 49.3mm
8	1	117-29	Locknut, Nylon 3/8-16 Zn	48	2x1		Seal, Primary, 19mm (See Ref. 55)
9	2	612-124	Arm, Steering	49	2x1	168-10	Piston 19mm dia.
10	1	612-106	Clamp, Lower Handlebar	50	2x1		Seal, Secondary, 19mm (See Ref. 55)
11	1	612-105	Clamp, Upper Handlebar	51	2x1		Boot, Rubber (See Ref. 55)
12	1	106-07	Ring, Retaining SH-0075PA	52	2	112-02	SHSS 10-24x1/4 Knurl Cup PT, PL
14	2	105-16	Bushing, Oilite - 3/4 x 1/2	53	2x2	160-01	Washer, Copper 2.3 x 10.0 x 16.0
15	2	110-17	Key, 3/16 x 3/16 x .625	54	2x1	160-44	Bolt, Banjo M10 x 1,0 x 21,0 Zn
16	2	128-10	Retainer, Handbrake Cable	55	2x1	161-25	O-Ring Kit, Master Cylinder - Grimeca (incl. Ref. 48, 50 & 51)
17	4	112-47	SHCS, 1/4-20 x 1.0 Zn	56	2	812-30	Pin, Female
18	8	117-27	Locknut, Nylon 1/4-20 Zn	57	2	117-03	Nut, Fin Hex 1/4-20 Zn
19	2	103-66	HHCS, 1/4-20 x 4.0 Gr5 Zn	58	2	812-31	Fin, Male
20	4	108-08	Washer, .28 x .62 x .04 Zn	59	2	160-45	Bolt, Banjo
21	2	812-17	Collar	60	4	160-04	Washer, Copper - 2,3 x 10,0 x 16,0
22	1	128-08	Lever Assembly, Handbrake	61		126-19	Fluid, Brake-Silicon Dot 5 - .35L
23	1	128-09	Cable Assembly, Handbrake				
24	2	127-35	Grip, Molded				
25	1	127-81	Throttle Twist Grip				
26	1	612-101	Cable Asm., Throttle				
27	1	100-64	Tie Wrap - 5.5" - Black				
28	2	161-05	O-Ring Kit, Knott Caliper				
29	2		Seal, Piston				
30	2		Seal, Rubber				
31	2x1	168-20	Plug, Rubber				
32	1	170-03	Pad Set (4), Brake - Non-Asbestos				
33	2x2	168-07	Pin, Cotter 1/8 x 3.00 Zn				
34	2x2	168-01	Piston, Knott Caliper				
35	2x1	163-01	Hose Asm, Hydraulic-310mm				
36	2	112-159	BHCS, 1/4-20 x 1.0, Plated				
37	1	166-10	Caliper, Hydraulic Brake - L, w/o pads				
38	1	166-11	Caliper, Hydraulic Brake - R, w/o pads				
39	2x8	108-24	Washer, .34x.70x.06 Zn				

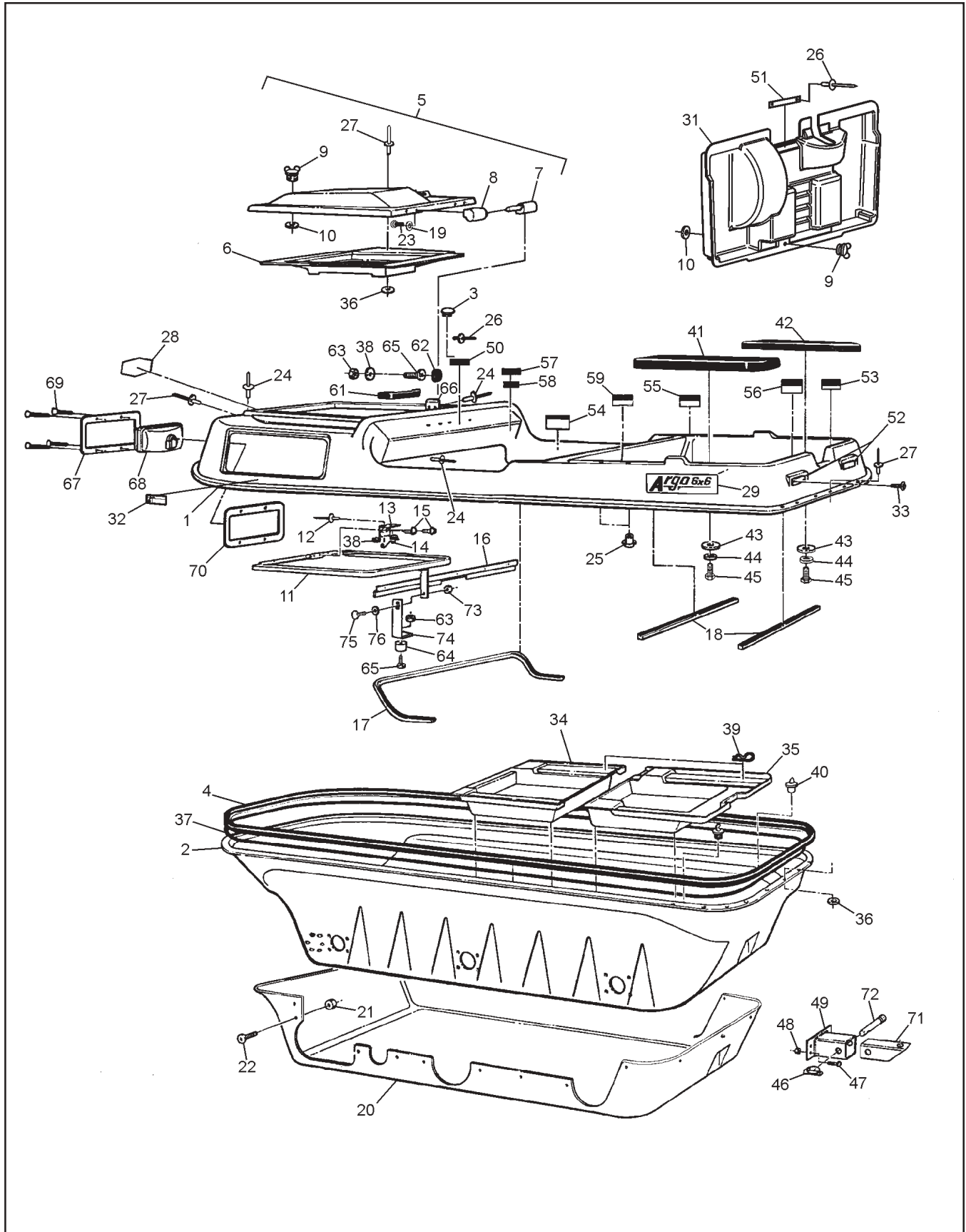

Bigfoot Parts Manual

6.0 Vehicle Body & Firewall

Ref.	Qty.	Part #	Description
1	1	601-32	Body & Hood, Upper - Bigfoot Replacement, specify colour (incl. Ref 5, 11, 12, 13, 14, 15 & 38)
2	1	603-92	Body, Lower - Ext'd 6x6, specify colour
3	1	127-28	Plug, Nylon - Black
4	1	601-05	Bumper, Vinyl - 6x6
5	1	602-37	Hood Kit (specify colour) (incl. Ref 6 to 10, 19, 23, 27, 36 & 66)
6	1	801-47	Duct, Intake Transition (specify colour)
7	2	127-45A	Pin, Hinge
8	2	127-45B	Knuckle, Hinge
9	2	126-10	Wing Stud
10	2	126-09	Grommet, Alum.
11	1	602-24	Hood Frame Assembly
12	2	120-15	Rivet 1/8 x 7/16
13	1	601-69	Spring Plate
14	1	126-11	Spring
15	2	112-19	Screw, IHWH T/C Slot 1/4-20x1/2
16	1	602-29	Brace, Dash
17	1	601-08	Vinyl Trim, 84"
18	2	601-09	Vinyl Trim, 28"
19	8	108-59	Lockwasher #10 Int. Tooth Zn
20	1	663-11	Skid Plate - Ext'd 6x6
21	26	120-28	Collar, Magna Grip
22	26	120-27	Pin, Magna Grip
23	8	103-47	HHCS 10-24x1/2 Zn
24	12	120-13	Rivet 3/16 x 5/8 - Black
25	4	117-44	T-Nut 1/4-20 Zn
26	34	120-24	Rivet, Alum - 3/32x3/8
27	76	120-09	Rivet 3/16 x 1 - Black
28	1	601-44	Nameplate, ARGO
29	2	127-66	Nameplate, 6x6 Bigfoot
31	1	609-41RM	Firewall - Handle Bar Steering
32	1	127-144	Label, Warning - HOT
33	4	103-48	T/S Pan HD Phil #10x5/8 A Zn
34	1	603-02	Floor Pan, Front (specify colour)
35	1	603-03	Floor Pan, Rear 6x6 (specify colour)
36	51	120-04	Washer .19x.50x.08 Zn
37	1	126-60	Vinyl Strip 1/2"x1/4"x37.5'
38	4	120-05	Washer .19x.50x.04 Zn

Ref.	Qty.	Part #	Description
39	4	100-16	Clip, Hitch Pin 1.625 Zn
40	2	100-18	Plug, Drain 5/8" x 13/32"
41	1	601-03	Seat, Rear LH - 6x6
42	1	601-02	Seat, Rear RH - 6x6
43	2	603-15	Washer, Plastic
44	2	108-01	Washer, Fender 1/4BSx1.25 OD
45	2	103-08	HHCS 1/4-20x1.0 Zn
46	1	104-11	Pin, Lynch
47	4	103-61	HHCS 3/8-24x1.5 Gr5 Zn
48	4	117-24	Locknut, Nylon 3/8-24 Zn
49	1	616-16	Hitch Assembly
50	1	127-153	Plate, Keyswitch
51	1	127-152	Shifting Plate
52	2	127-01	Reflector, Red
53	1	126-67	Floor Pan Plate
54	1	126-68	Operation Plate
55	1	126-69	Fuel Plate
56	1	127-76	Plate, Capacity - Land/Water
57	1		Vehicle ID Plate
58	1		U.S. Plate, Non U.S. Argos only
59	1	127-51	Plate, Capacity - 6x6
61	1	125-41	Dash Handle, incl. 62
62	2		Plug cap, avail. only with 61
63	3	117-10	Locknut, Nylon #10-24 Zn
64	1	126-88	Bumper, Rubber
65	3	103-25	PHMS 10-24x3/4 Zn
66	1	602-38	Clip, Hood
67	2	613-75	Bezel, Headlamp
68			See Section 9.0 Electrical System
69	8	103-24BL	OHPS T/S #6 x 1.0 Black Zn
70	2	613-76	Bracket, Headlight Backing
71	1	616-19	Tube, Hitch - Insert
72	1	104-13	Pin, Top Link
73	1	117-15	Nut, Fin. Hex 3/8-16 Zn
74	1	602-27	Support, Adjustable
75	1	103-89	C/Bolt 3/8-16x3/4 Gr2 Zn
76	1	108-06	Lockwasher 3/8 Zn

Ref.	Qty.	Part #	Description
1	1	606-60	Frame Asm - 6x6 Bigfoot
2	2	606-24	Gasket, Bearing Extension
3	64	117-15	Nut, Fin Hex 3/8-16 Zn
4	12	108-46	Washer .40x1.37x.12 Hi-Carbon
5	10	101-35	Bearing, Ball - 1.25
5a	6	101-41	Bearing, Ball - 1.0
6	66	108-06	Lockwasher 3/8 Zn
7	22	103-88	C/Bolt 3/8-16x1.0 Gr5 Zn
9	12	605-89	Gasket, Outer Bearing Flange
10a	16	605-63	Flange - 4-hole
10b	6	101-20	Flange Greaseable - 4 Hole
11	6	102-14	Seal, Oil 1.25x1.75x0.188
12	6	102-15	Seal, Oil 1.25x1.874x0.25
13	6	605-97	Flange Assem, Outer (incl. Refs. 11 & 12)
14	16	112-39	C/Bolt 3/8-16x1.75 Gr5 Zn
15	8	112-134	C/Bolt 3/8-16 x 6.5 Zn
16	2	810-52	Bearing Extension (uses Refs. 17 & 18)
17	12	108-34	Washer 7/16 SAE Zn
18	12	103-81	HHCS 7/16-20x2.5 Gr5 Zn
19	5x6	103-80	Stud, Wheel 7/16-20 x 1.125 #B271
20	2	810-73	Axle Assembly - Front (incl. Ref. 19)
21	4	810-75	Axle Assembly - Mid (incl. Ref. 19)
22	2	810-32	Shaft, Idler - 11T
23	1	604-84	Frame Assembly, Battery
24	6	810-28	Sprocket, Double - 24T
25	4	606-34	Sprocket - S60x19T
26	6	112-03	SHSS 5/16-18x3/8 1/2 DOG, PL
27	2	803-17	Chain, Idler RC50-2 x 40P (incl. Ref 53)
28	4	117-64	Insert, 1/4-20
29	10	112-31	HHCS 3/8-16 x 1.0 2B Gr8 Zn
30	2	112-14	HHCS 3/8-16x.75 Gr5 Zn
31	1	108-15	Washer 3/8 SAE Zn
32	2	103-82	HHCS 3/8-16x1.5 Gr5 Zn
33	4	112-61	C/Bolt 3/8-16x1.25 Gr5 Zn
34	2	120-15	Rivet 1/8 x 7/16
35	1	126-11	Spring
36		127-80	Link, Half - RC60 - 1 (opt.)
37	4	101-80	Flange, greaseable - 90 Degree
43	2	603-17	Chain RC50 - 2x42P - Front (incl. Ref 53)
44	2	603-26	Chain RC50 - 2x76P - Mid (incl. Ref 53)
45	2	603-83	Chain RC60 - 1x88P - Rear (incl. Ref 54)
46	5x6	117-35	Nut, Wheel 7/16-20 Zn
47	6	125-26	Valve, Tire
48	6	127-61C	Rim - 10x9 - Charcoal
49	6	127-60	Tire, Goodyear Rawhide III 25x12-9
52	4	100-01	Pin, Cotter 1/8 x 1.50 Zn
53	1x6	100-96	Con. Link, RC50-2 H.D.
54	1x2	603-84	Con. Link, RC60-1 H.D.
55	4	127-65	Spring Torsion - 1.16x0.35
56	4	606-39	Slider Block - 1/2" Shaft
57	4	606-35	Tensioner Asm, Chain
58	4	127-64	Spring, Torsion - .76 x 1.9
59	2	107-10	Retaining Ring
60	2	606-41	Slide, Chain - 2"
61	2	606-42	Slide, Chain - 1.25"
62	6	603-95	Spring Clip - RC 50 Closed
63	4	603-96	Spring Clip - RC 60 Closed

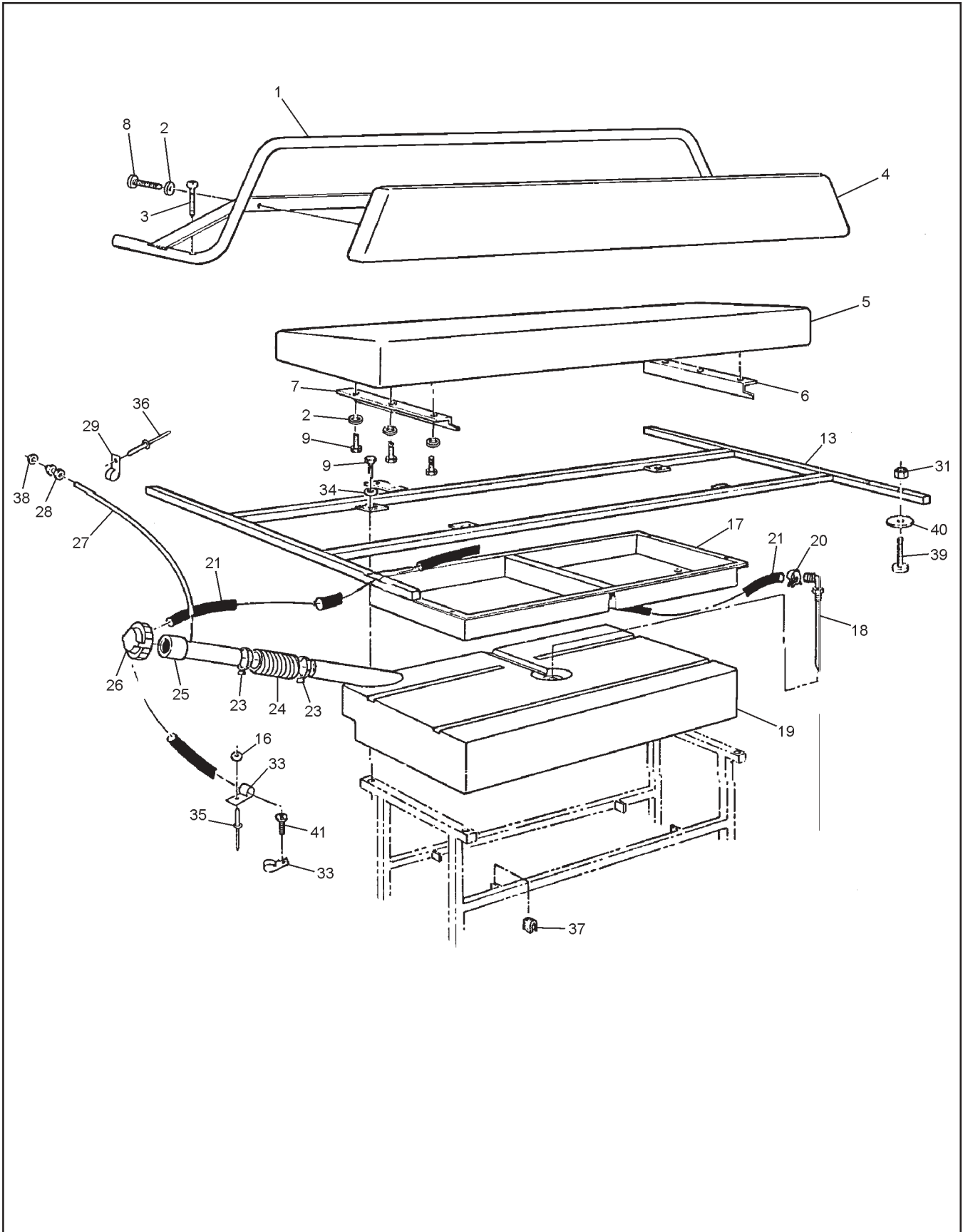

Bigfoot Parts Manual 8.0 Fuel System & Seat Assembly

Ref.	Qty.	Part #	Description
1	1	803-50	Handrail Assembly
2	10	108-03	Lockwasher 1/4 Zn
3	2	112-41	PHMS, Phil 1/4-20 x 1.25 Zn
4	1	608-39	Back Pad Assembly
5	1	608-43	Seat, Bench
6	1	608-30	Angle, Left
7	1	608-31	Angle, Right
8	4	103-03	PHMS, Phil 1/4-20 x 1.50 Zn
9	10	112-04	HHCS 1/4-20 x 3/4 Gr2 Zn
13	1	804-17	Frame Assembly, Seat
16	3	120-04	Washer .19 x .50 x .08 Zn
17	1	608-32	Tool Box
18	1	608-28	Pickup Assembly, Fuel (see Ref. 19)
19	1	608-24	Tank, Fuel 32 litre (incl. Ref. 18)
20	2	112-79	Clamp, Hose, 1/2" - Black
21	1	608-42	Fuel Hose - 110"
23	2	100-12	Clamp, Gear 2.25" HF-36
24	1	125-94	Hose, Filler
25	1	126-47	Fuel Neck Assembly
26	1	126-46	Cap, Fuel
27	1	126-77	Hose, Vent 93" 6x6
28	1	126-50	Male Connector, 1/4"
29	5	126-94	Clamp, Nylon Wire - 1/4" ID
31	12	117-10	Locknut, Nylon #10-24 Zn
33	4	126-93	Clamp, Nylon Wire - 1/2" ID
34	4	108-08	Washer, .28 x .62 x .04 Zn
35	3	120-09	Rivet 3/16x1 - Black
36	6	120-13	Rivet, 3/16 x 5/8 - Black
37	4	702-06	Foam Cushion
38	1	117-54	Locking PAL Nut, 1/2-20
39	12	112-07	RHMS 10-24 x 1.50 Zn
40	12	108-42	Washer .21x1.0x.06 Zn
41	1	103-48	T/S Pan HD Phil #10x5/8 A Zn

9.0 Electrical System

Bigfoot Parts Manual

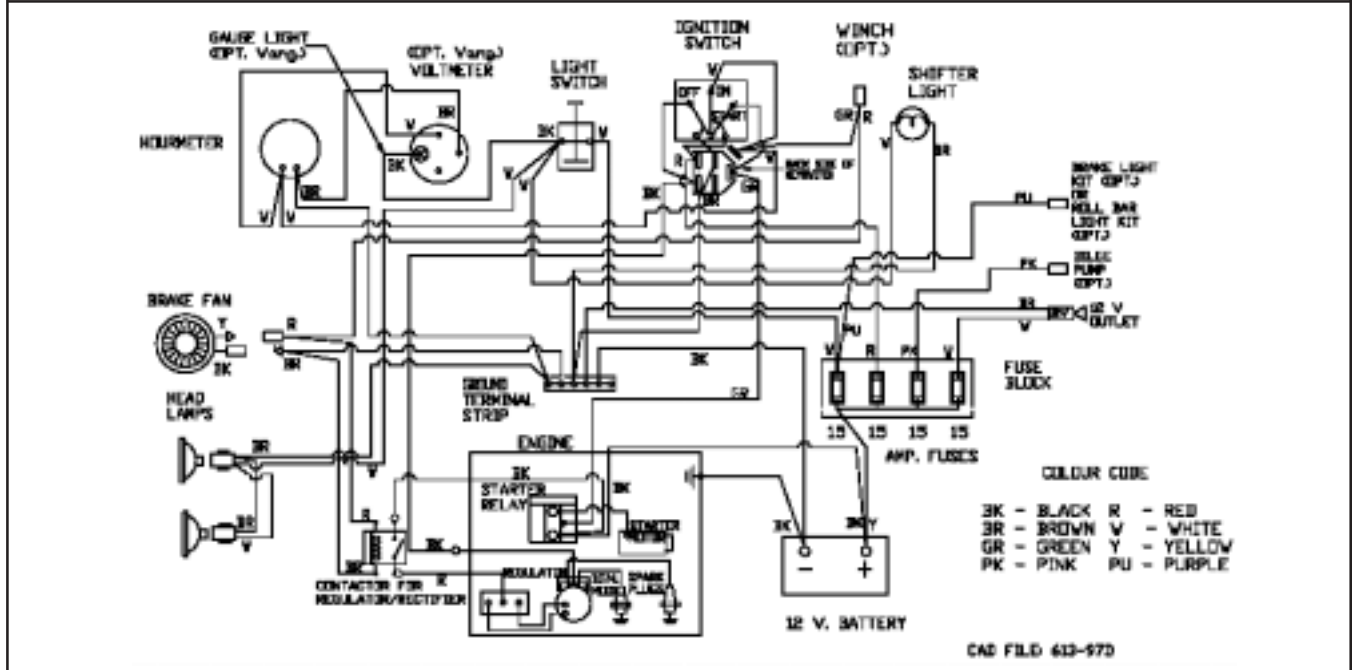
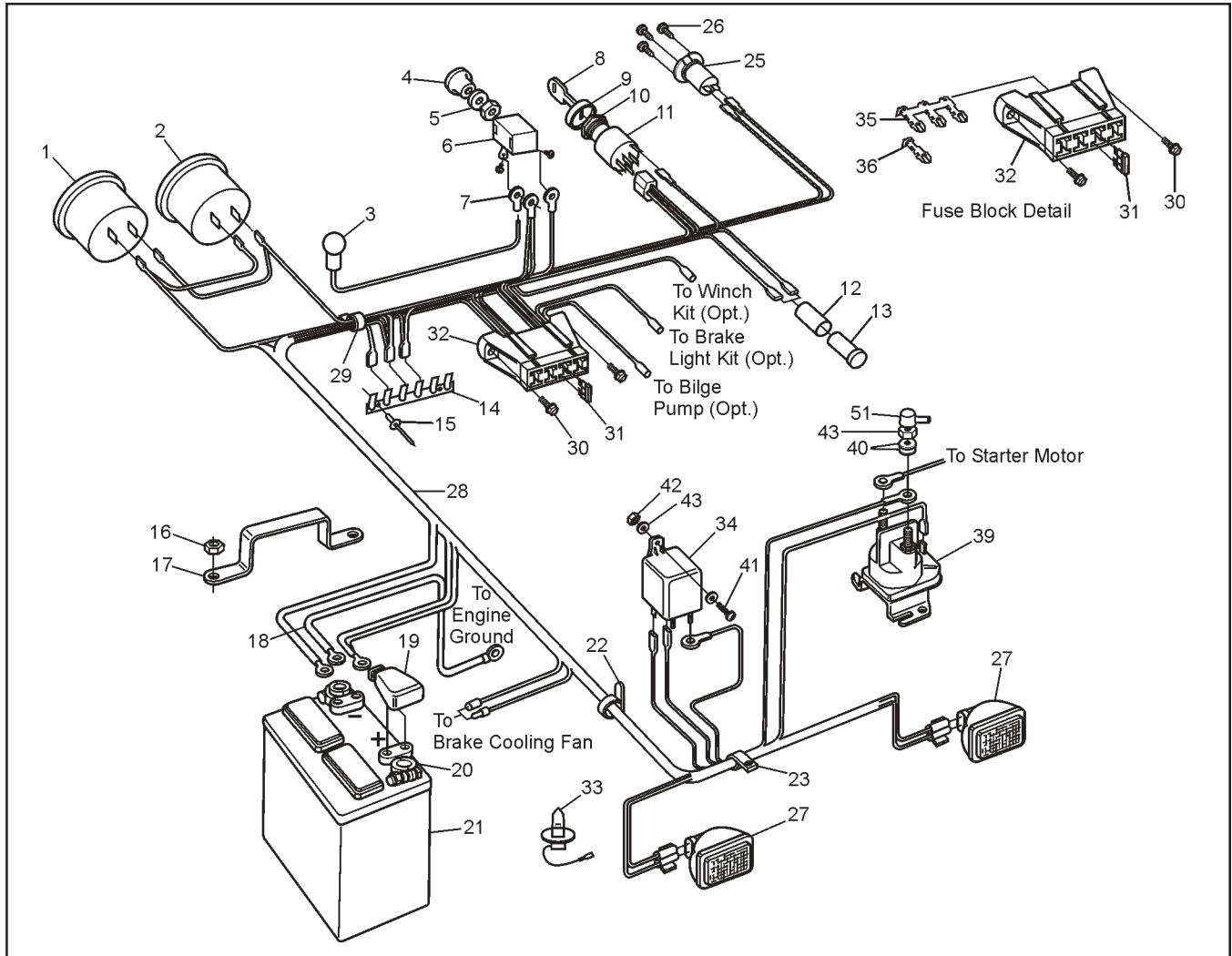

Ref.	Qty.	Part #	Description
1	1	632-15	Hourmeter #56458-10 (#876EM)
2	1	633-10	Voltmeter #07583-15 (#830EM)
3	2	634-10	Light Kit, #06215-00 5/8" dia.
4	1	126-76	Knob, Light
5	1	108-55	Lockwasher 7/16 Ext. Tooth
6	1	100-62	Switch, Light
7	1	118-30	Terminal, Eye - #10
8	2	127-108	Key,molded
9	1	127-107	Cover, nut
10	1	127-106	Nut, flanged - plastic
11	1	127-105	Switch - Egnition
12	1	118-48	Heat Shrink
13	1	634-08	Light, Indicator
14	1	613-37	Terminal Strip, Ground
15	2	120-15	Rivet 1/8 x 7/16
16	2	117-21	Locknut, Nylon 5/16-18 Zinc
17	1	604-52	Bracket, Battery Retaining
18	1	613-14	Ground Wire
19	1	127-55	Cap, Battery Terminal - Red
20	2	127-56	Terminal, Battery Post
21	1	127-54	Battery
22	8	100-64	Tie Wrap - 5.5" - Black
23	10	126-93	Clamp, Nylon Wire - 1/2" ID
24	1	127-154	Label, Fuse Panel (located on Guard, Belt Protect - see pg. 5)
25	1	613-90	Outlet, 12 V DC
26	3	112-139	#4 Phil Drive Oval Head Screw, Black
27	2	613-69	Headlamp, Halogen (incl. Ref. 33)
28	1	613-97	Wire Harness
29	1	127-24	Clamp, Nylon - 1" ID
30	2	112-51	Screw, IHWH T/C #10-24 x 5/8
31	4	118-49	Fuse, 15 A 2-prong (AT015)
32	1	118-60	Block Fuse - 8 position (4 fuse)
33	2	127-46	Bulb, Headlight - Halogen
34	1	613-98	Relay, 80 Amp
35	1	118-63	Terminal, Fuse - Triple
36	5	118-62	Terminal, Fuse - Single
37	1	613-45	Insulator, Terminal (6 ga.)
38	2	117-20	Nut, Fin. Hex 1/4-20 Zn
39	1	613-68	Starter Relay
40	5	108-03	Lockwasher 1/4 Zn
41	1	103-25	PHMS 10-24 x 3/4 Zn
42	1	117-10	Locknut, 10-24 N/I Zn
43	2	120-05	Washer .19 x .50 x .04 Zn

***ARGO* Products Manufactured by:**

Ontario Drive & Gear Limited

220 Bergey Court
New Hamburg, Ontario
Canada N3A 2J5
Phone: (519) 662-2840
Fax: (519) 662-2421

ODG *Dedicated to quality and performance*